



Rubber Sheet Roll

TECHNICAL DATA SHEET

MIL R 6855 E MILITARY SPECIFICATION (1992)

SUPERCEDED BY SAE-AMS-R-6855 (1998)

ELASTOMER, SYNTHETIC, SHEETS,

SOLID, MATERIAL.



MIL R 6855 E - Technical Specification Data

MIL R 6855 E SYNTHETIC RUBBER SHEET will resist most oils, not effected by sunlight or harsh environmental extremes. **MIL R 6855 E** maintains superior flexibility in hot or cold conditions, and also has the resiliency to maintain temperature and environmental cycles. The synthetic material is configured based on Type and Class. This specification data covers the governing MIL SPEC call out, not individual classes or types. Certifications are available for classes and type variations.

COLOR:	BLACK
SURFACE:	SMOOTH
TEMPERATURE RANGE:	SEE ATTACHED DOC
TENSILE:	SEE ATTACHED DOC
DUROMETER:	60A NOMINAL
ELONGATION:	SEE ATTACHED DOC

RUBBER SHEET ROLL

PO BOX 171
Shippensburg, PA 17257
Phone: 866.834.8606
Fax: 888.440.5797
E-mail: info@rubbersheetroll.com

Fire Rated: Not Fire Rated | **Chemical Resistance:** Moderate

UV Rated: Moderate | **Composition:** Synthetic Rubber



www.facebook.com/Rubber-Sheet-Roll

www.twitter.com/rubbersheetroll



NOTICE OF
REINSTATEMENT

INCH POUND

MIL-R-6855E
NOTICE 2
15 June 2001

SUPERSEDING
NOTICE 1
18 December 1998

MILITARY SPECIFICATION

RUBBER, SYNTHETIC, SHEETS, STRIPS, MOLDED OR EXTRUDED SHAPES,
GENERAL SPECIFICATION FOR

MIL-R-6855E, dated 31 July 1992, is hereby reinstated and may be used for acquisition.

Custodians:

Army - MR
Navy - AS
Air Force - 11
DLA - IS

Preparing activity:

Navy - AS

(Project 9320-0040)

Review activities:

Army - AR, AT, AV, CE, CR, MI
Navy - OS, SH, YD
Air Force - 82, 99
DLA - CC, GS

AMSC N/A

FSC 9320

DISTRIBUTION STATEMENT A. Approved for public release; distribution is unlimited.

NOTICE OF CANCELLATION

INCH-POUND

MIL-R-6855E
NOTICE 1
18 December 1998

MILITARY SPECIFICATION

ELASTOMER, SYNTHETIC, SHEETS, STRIPS, MOLDED OR EXTRUDED SHAPES,
GENERAL SPECIFICATION FOR

MIL-R-6855E, dated 31 July 1992, is hereby canceled. Future acquisition for this material should refer to SAE-AMS-R-6855, "Elastomer, Synthetic, Sheets, Strips, Molded or Extruded Shapes, General Specification for".

(Application for copies of SAE - Aerospace Material Specifications should be addressed to SAE, 400 Commonwealth Drive, Warrendale, PA 15096.)

Preparing activity:
Navy - AS

(Project 9320-0022)

AMSC N/A

FSC 9320

DISTRIBUTION STATEMENT A. Approved for public release; distribution is unlimited.

INCH-POUND
MIL-R-6855E
SUPPLEMENT 1
31 July 1992

MILITARY SPECIFICATION

**RUBBER, SYNTHETIC, SHEETS, STRIPS, MOLDED OR EXTRUDED SHAPES,
GENERAL SPECIFICATION FOR**

THIS SUPPLEMENT FORMS A PART OF MIL-R-6855E, DATED 31 JULY 1992

SPECIFICATION SHEETS

MIL-R-6855/1 - Rubber, Synthetic, Sheets.
MIL-R-6855/2 - Rubber, Synthetic, Strip (or Tape).
MIL-R-6855/3 - Rubber, Synthetic, Rods (or Rounds).
MIL-R-6855/4 - Rubber, Synthetic, Tubing.
MIL-R-6855/5 - Rubber, Synthetic, Channel, Extruded.
MIL-R-6855/6 - Rubber, Synthetic, Special Shape, Extruded.

**Preparing Activity:
Navy - AS**

AMSC: N/A

1 of 1

FSC 9320

DISTRIBUTION STATEMENT A: Approved for public release; distribution is unlimited.

INCH-POUND
MIL-R-6855E
31 July 1992
SUPERSEDING
MIL-R-6855D
16 February 1987

MILITARY SPECIFICATION

RUBBER, SYNTHETIC, SHEETS, STRIPS, MOLDED OR EXTRUDED SHAPES, GENERAL SPECIFICATION FOR

This specification is approved for use by all Departments
and Agencies of the Department of Defense.

1. SCOPE

1.1 Scope. This specification covers the requirements for low temperature resistant sheets, strips, and molded or extruded shapes fabricated from synthetic rubber (see 6.1).

1.2 Classification. The Classes, Types, Grades, and Forms of synthetic rubber covered by this specification are as specified herein (see 6.2). Type A material may also be supplied as Type B material.

1.2.1 Class and type (see 6.1).

Class 1	Fuel and petroleum oil resistant
Class 2	Petroleum oil, weather and ozone resistant
Type A	High ozone concentration
Type B	Low ozone concentration
Class 3	Non-oil resistant
Class 4	Petroleum oil, weather and ozone resistant (for use in contact with acrylic and polycarbonate plastics)
Type A	High ozone concentration
Type B	Low ozone concentration
Class 5	Non-oil resistant (for use in contact with acrylic and polycarbonate plastics)

Beneficial comments (recommendations, additions, deletions) and any pertinent data which may be of use in improving this document should be addressed to: Commanding Officer, Naval Air Warfare Center Aircraft Division Lakehurst, Code SR3, Lakehurst, NJ 08733-5100, by using the self-addressed Standardization Document Improvement Proposal (DD Form 1426) appearing at the end of this document or by letter.

AMSC N/A

FSC 9320

DISTRIBUTION STATEMENT A: Approved for public release; distribution is unlimited.

1.2.2 Grade. The grade designation numbers below correspond to the nominal Shore A-2 durometer hardness values.

30	60
40	70
50	80

1.2.3 Form. Forms covered by this specification are as follows:

- Sheet
- Strip (or tape)
- Extruded shapes
- Molded shapes

2. APPLICABLE DOCUMENTS

2.1 Government Documents.

2.1.1 Specifications, standards and handbooks. The following specifications, standards, and handbooks form a part of this document to the extent specified herein. Unless otherwise specified, the issues of these documents shall be those listed in the issue of the Department of Defense Index of Specifications and Standards (DODISS) and supplement thereto, cited in the solicitation (see 6.2).

SPECIFICATIONS

FEDERAL

TT-N-95	-	Naphtha, Aliphatic.
PPP-B-601	-	Boxes, Wood, Cleated Plywood.
PPP-B-636	-	Boxes, Shipping, Fiberboard.
PPP-B-640	-	Boxes, Fiberboard, Corrugated, Triple-Wall.

MILITARY

MIL-P-4861	-	Packing, Preformed, Rubber, Packaging of.
MIL-P-5425	-	Plastic Sheet, Acrylic, Heat Resistant.
MIL-P-83310	-	Plastic Sheet, Polycarbonate, Transparent.

STANDARDS

MILITARY

MIL-STD-105	-	Sampling Procedures and Tables for Inspection by Attributes.
MIL-STD-129	-	Marking for Shipment and Storage.
MIL-STD-147	-	Palletized Unit Loads.
MIL-STD-190	-	Identification Marking of Rubber Products.
MIL-STD-289	-	Visual Inspection Guide for Rubber Sheet Material.
MIL-STD-298	-	Visual Inspection Guide for Rubber Extruded Goods.
MIL-STD-407	-	Visual Inspection Guide for Rubber Molded Items.
MIL-STD-2073-1	-	DOD Material Procedures for Development and Application of Packaging Requirements.

HANDBOOKS

MILITARY

MIL-HDBK-695 - Rubber Products: Recommended Shelf Life

(See supplement 1 for a list of associated specifications.)

(Unless otherwise indicated, copies of federal and military specifications, standards, and handbooks are available from the Standardization Documents Order Desk, Bldg. 4D, 700 Robbins Avenue, Philadelphia, PA 19111-5094.)

2.2 Non-Government publications. The following documents form a part of this document to the extent specified herein. Unless otherwise specified, the issues of the documents which are DOD adopted are those listed in the issue of the DODISS cited in the solicitation. Unless otherwise specified, the issues of documents not listed in the DODISS are the issues of the documents cited in the solicitation (see 6.2).

AMERICAN SOCIETY FOR TESTING AND MATERIALS (ASTM)

ASTM D395 - Rubber Property - Compression Set.
 ASTM D412 - Rubber Properties in Tension.
 ASTM D471 - Rubber Property - Effect of Liquids.
 ASTM D518 - Rubber Deterioration - Surface Cracking.
 ASTM D792 - Specific Gravity and Density of Plastics by Displacement.
 ASTM D1149 - Rubber Deterioration - Surface Ozone Cracking in a Chamber.
 ASTM D2240 - Rubber Property - Durometer Hardness.
 ASTM D3951 - Standard Practice for Commercial Packaging.

(Application for copies should be addressed to the American Society for Testing and Materials, 1916 Race Street, Philadelphia, PA 19103.)

2.3 Order of precedence. In the event of a conflict between the text of this document and the references cited herein (except for related associated detail specifications, specification sheets, or MS standards), the text of this document takes precedence. Nothing in this document, however, supersedes applicable laws and regulations unless a specific exemption has been obtained.

3. REQUIREMENTS

3.1 First article. Unless otherwise specified (see 4.3.2, 6.2 and 6.6), first article inspection shall be performed in accordance with 4.3.

3.2 Specification sheets. The synthetic rubber sheets, strips, molded or extruded shapes requirements shall be as specified herein and in accordance with the applicable specification sheet or other governing document when the end item is not covered by a specification sheet. In the event of any conflict between the requirements of this specification and the specification sheet, the latter shall govern.

3.3 Materials. Material supplied to this specification shall have no adverse effect on the finished surfaces of wood, metal, or cloth with which it may come in contact.

3.3.1 Polyurethane. Polyurethane material shall be excluded under this specification.

3.4 Dimensions and tolerances. Dimensions and tolerances for rubber components supplied to this document shall be as specified in the specification sheet, drawing, contract or purchase order (see 6.2). When tolerances are not specified for sheet, strip, tubing, or rod, they shall be in accordance with 3.4.1 for sheet and strip and 3.4.2 for tubing and rod.

3.4.1 Sheet and strip. When not specified (see 3.4), the tolerances for width and thickness shall be as specified in Tables I and II respectively. Laminating thinner sheets and strip to obtain specified thicknesses shall not be allowed. The tolerance for length shall be the specified length -0 with no limitation on the plus tolerance.

TABLE I. Width tolerances for sheet and strip.

Dimensions, inches (mm)	Tolerances
Less than .5 (12.7)	± 8 percent
.5 (12.7) through 2 (50.8)	± 5 percent
Over 2 (50.8)	± 3 percent

TABLE II. Thickness tolerances for sheet and strip.

Nominal Thickness, inches (mm)	Tolerances
Under .031 (0.79)	± 20 percent
.031 (0.79) to .062 (1.59) inclusive	± 18 percent
Over .062 (1.59) to .125 (3.2) inclusive	± 16 percent
Over .125 (3.2) to .187 (4.8) inclusive	± 15 percent
Over .187 (4.8) to .375 (9.5) inclusive	± 14 percent
Over .375 (9.5) to .562 (14.3) inclusive	± 13 percent
Over .562 (14.3) to .750 (19.1) inclusive	± 12 percent
Over .750 (19.1) up to 1.00 (25.4) inclusive	± 11 percent
Over 1.00 (25.4)	± 10 percent

3.4.2 Tubing and rod. When not specified (see 3.4), tolerances for tubing and rod shall be as specified in Tables III and IV respectively.

TABLE III. Tubing tolerances. 1/

Nominal Wall Thickness, inches (mm)	Tolerance, inches (mm)
.047 (1.19) and under	+ .016 (.40), -0
over .047 (1.19) to .125 (3.20) inclusive	± .016 (.40)
over .125 (3.20) to .156 (3.97) inclusive	± .023 (.60)
over .156 (3.97) to .250 (6.40) inclusive	± .031 (.79)
over .250 (6.40)	± 10 percent

1/ - The tolerance for all nominal inside diameters from .125 (3.2) to 1.750 (44.45) shall be ± .016 (.40).

TABLE IV. Rod tolerances.

Nominal Diameter, inches (mm)	Tolerance, inches (mm)
under .156 (3.97) to .250 (6.40) inclusive	+ .031 (.79), - .016 (.40)
over .250 (6.40) to .500 (12.70) inclusive	± .031 (.79)
over .500 (12.70) to 1.000 (25.40) inclusive	± .047 (1.19)
over 1.000 (25.40) to 1.500 (38.10) inclusive	± .062 (1.57)
over 1.500 (38.10)	± 10 percent

3.5 Surface finish. Unless otherwise specified on the drawing, specification sheet, contract, or purchase order (see 6.2), the surfaces of the material shall be smooth and free from cloth imprint.

3.6 Physical and mechanical properties. Physical and mechanical properties of Classes 1, 2 and 3 synthetic rubber shall conform to Table V. Physical and mechanical properties of Classes 4 and 5 synthetic rubber shall conform to Table VI.

3.6.1 Ozone resistance. Classes 2 and 4 synthetic rubber shall show no signs of ozone cracking after being conditioned and tested under Type A for high ozone concentration, or Type B for low ozone concentration as specified in 4.6.1.4.

3.6.2 Crazing. Classes 4 and 5 synthetic rubber material shall not craze acrylic or polycarbonate plastic sheet when tested as specified in 4.6.1.5.

3.6.3 Low temperature resistance.

3.6.3.1 Cold bend. The synthetic rubber, when subjected to the tests of 4.6.4, shall show no evidence of cracking.

3.7 Color. If material covered by this specification is required to be of a specified color, the color requirement and color quality assurance provisions shall be as stated in the contract or purchase order (see 4.7 and 6.2).

3.8 Shelf life. Shelf life requirements, based on the type of material and conditions of storage and use, shall be as specified in the contract or purchase order (see 6.2). MIL-HDBK-695 shall be used as guidance for specifying shelf life, unless another document is specified. Product identification markings shall include the cure date and the "use by" date of the material which shall be based on the cure date (see 5.3.1).

TABLE V. Physical and mechanical properties - Classes 1, 2 and 3.

Class	Properties Under Standard Conditions			Properties After Accelerated Aging (Oven aged 70 ± 1 hours at 212 ± 2°F) (100 ± 1°C)				Properties After Immersion									
	Hard. pts.	Ten. St. min. (Psi) (MPa)	Elong. min. (%)	Sp. Gr. unit	Comp. Set (max. %)	Change In			Change in			Change in volume					
						Hard. pts.	Ten. st. max. (%)	Elong. max. (%)	Wt. max. (%)	Hard. pts.	Vol. (%)	Ten. st. max. (%)	Vol. (%)	Aromatic type	Alkylate type	Post immersion test	
																	Oil
1	30±5	1,000 (6.90)	500	2/	40	+20 -0	-20	-50	-10	±10	+25 -0	±30 -0	±10 -30	+40	-1	-10	
	40±5	1,100 (7.60)	450	2/	40	+20 -0	-20	-50	-10	±10	+20 -0	±30 -0	±10 -30	+35	-1	-10	
	50±5	1,200 (8.30)	350	2/	40	+20 -0	-20	-50	-10	±10	+20 -0	±30 -0	±10 -30	+30	-1	-15	
	60±5	1,300 (9.00)	300	2/	40	+20 -0	-20	-50	-10	±10	+15 -0	+25 -0	±10 -25	+30	-1	-8	
	70±5	1,400 (9.70)	200	2/	40	+20 -0	-20	-50	-10	±10	+15 -0	+25 -0	±10 -20	+30	-1	-7	
	80±5	1,600 (11.0)	150	2/	40	+15 -0	-20	-50	-10	±10	+15 -0	+20 -5	±10 -20	+25	-1	-5	
	30±5	1,200 (8.30)	500	2/	50	+15 -5	-15	-40	-10	±15	+35 -0	±10	±10	±10	---	---	---
	40±5	1,300 (9.00)	500	2/	50	+15 -5	-15	-40	-10	±15	+30 -0	±10	±10	±10	---	---	---
	50±5	1,500 (10.3)	350	2/	50	+15 -5	-15	-40	-10	±15	+30 -0	±10	±10	±10	---	---	---
	60±5	1,500 (10.3)	300	2/	50	+15 -5	-15	-40	-10	±15	+25 -5	±10	±10	±10	---	---	---
2	70±5	1,600 (11.0)	200	2/	50	+15 -5	-15	-40	-10	±15	+25 -0	±10	±10	±10	---	---	---
	80±5	1,600 (11.0)	150	2/	50	+15 -5	-15	-40	-10	±10	+20 -0	±10	±10	±10	---	---	---
	30±5	1,000 (6.90)	450	2/	40	+15 -0	-20	-40	-10	±10	+20 -0	±10	±10	---	---	---	
	40±5	1,000 (6.90)	400	2/	40	+15 -0	-20	-40	-10	±10	+20 -0	±10	±10	---	---	---	
	50±5	1,500 (10.3)	300	2/	40	+15 -0	-20	-40	-10	±10	+20 -0	±10	±10	---	---	---	
	60±5	1,500 (10.3)	200	2/	40	+15 -0	-20	-40	-10	±10	+20 -0	±10	±10	---	---	---	
	70±5	1,500 (10.3)	200	2/	40	+15 -0	-20	-40	-10	±10	+20 -0	±10	±10	---	---	---	
	80±5	1,500 (10.3)	150	2/	40	+15 -0	-20	-40	-10	±10	+15 -0	±10	±10	---	---	---	
	3	30±5	1,000 (6.90)	500	2/	40	+15 -0	-20	-40	-10	±10	+20 -0	±10	±10	---	---	---
		40±5	1,000 (6.90)	400	2/	40	+15 -0	-20	-40	-10	±10	+20 -0	±10	±10	---	---	---
50±5		1,500 (10.3)	350	2/	40	+15 -0	-20	-40	-10	±10	+20 -0	±10	±10	---	---	---	
60±5		1,500 (10.3)	300	2/	40	+15 -0	-20	-40	-10	±10	+20 -0	±10	±10	---	---	---	
70±5		1,500 (10.3)	200	2/	40	+15 -0	-20	-40	-10	±10	+20 -0	±10	±10	---	---	---	
80±5		1,500 (10.3)	150	2/	40	+15 -0	-20	-40	-10	±10	+15 -0	±10	±10	---	---	---	

1/ Phase A, Phase B, and Phase C tests shall be conducted successively on the same specimens.

2/ "As determined" ± 3% of the nominal first article value.

TABLE VI. Physical and mechanical properties - Classes 4 and 5.

Class	Properties Under Standard Conditions				Properties After Accelerated Aging (Oven aged 70 ± 1 hours at 212 ± 2°F)				Properties After Immersion						
	Hard. pts.	Ten. st. min. psi (MPa)	Elong. min. (%)	Sp. Gr. unit	Comp. set (max. %)	Hard. pts.	Ten. st. max. (%)	Elong. max. (%)	Mt. max. (%)	Change In			Change In		
										Water	Oil	Vol. (%)	Hard. pts.	Ten. st. max. (%)	Vol. (%)
4	30±5	1,100 (7.60)	450	1/	50	+15	-15	-40	-10	±15	+35	±10	-35	±15	70 ± 1 hours at 110 ± 2°F (43 ± 1°C) No crazing
	40±5	1,200 (8.30)	450	1/	50	+15	-15	-40	-10	±15	+30	±10	-35	±15	
	50±5	1,300 (9.00)	350	1/	50	+15	-15	-40	-10	±15	+30	±10	-30	±15	
	60±5	1,500 (10.3)	300	1/	50	+15	-15	-40	-10	±15	+25	±10	-30	±15	
	70±5	1,500 (10.3)	200	1/	50	+15	-15	-40	-10	±10	+25	±10	-25	±15	
	80±5	1,500 (10.3)	150	1/	50	+15	-15	-40	-10	±10	+20	±10	-25	±15	
	30±5	1,000 (6.90)	450	1/	40	+15	-20	-40	-10	±10	+25	—	—	—	
	40±5	1,000 (6.90)	400	1/	40	+15	-20	-40	-10	±10	+25	—	—	—	
5	50±5	1,200 (8.30)	350	1/	40	+15	-20	-40	-10	±10	+20	—	—	—	70 ± 1 hours at 212 ± 2°F (100 ± 1°C) No crazing
	60±5	1,200 (8.30)	300	1/	40	+15	-20	-40	-10	±10	+20	—	—	—	
	70±5	1,300 (9.00)	200	1/	40	+15	-20	-40	-10	±10	+20	—	—	—	
	80±5	1,300 (9.00)	150	1/	40	+15	-20	-40	-10	±10	+15	—	—	—	

1/ "As determined" ± 3% of the nominal first article value.

3.9 Identification marking. The identification marking shall be in accordance with MIL-STD-190, except that colors indicating environmental resistance shall not be used. The fluid employed for marking shall be white in color, except that fluid employed for marking white synthetic rubber shall be black in color. The material shall be marked with the following:

- Part number (see 6.2.1), if any
- Manufacturers designation (compound number), for sheet and strip only
- Material class number (see 1.2.1), immediately followed by the material grade number in parenthesis (see 1.2.2), and the material type (see 1.2.1) for Classes 2 and 4; for example, Class 2, Grade 40, Type A, shall be marked 2 (40) A.
- The cure date and "use by" date (see 3.8) stated by year and quarter (for example: 4Q94 indicates the fourth quarter of calendar year 1994).

3.9.1 Marking frequency for sheet and strip. Unless otherwise specified in the contract or purchase order (see 6.2), the identification markings specified in 3.9 shall appear at least once on each square foot (.09 m²) of sheet and strip material 12 inches (30.5 cm) or more in width, and shall appear at least once on each linear foot of sheet or strip material less than 12 inches (30.5 cm) wide.

3.9.2 Marking frequency for extruded shapes. Unless otherwise specified in the contract or purchase order (see 6.2), the identification markings specified in 3.9 shall appear at least once for every 12 inches (30.5 cm) of length.

3.9.3 Marking for molded shapes and small pieces. Unless otherwise specified in the contract or purchase order (see 6.2), the identification markings specified in 3.9 shall appear once on the outside of the envelope in which the individual parts are furnished (see 5.1.1.1) in addition to the markings required in Section 5.

3.10 Workmanship. The elastomeric materials shall be compounded and processed such that the resulting material meets the requirements of this specification. Defects in workmanship shall be determined in accordance with 4.4.2.1. Extrusions 168 inches (426.6 mm) in length or less shall be cured in straight lengths to avoid longitudinal curvature which may impair serviceability.

4. QUALITY ASSURANCE PROVISIONS

4.1 Responsibility for inspection. Unless otherwise specified in the contract or purchase order, the contractor is responsible for the performance of all inspection requirements (examinations and tests) as specified herein. Except as otherwise specified in the contract or purchase order, the contractor may use his own or any other facilities suitable for the performance of the inspection requirements specified herein, unless disapproved by the Government. The Government reserves the right to perform any of the inspections set forth in the specification where such inspections are deemed necessary to ensure supplies and services conform to prescribed requirements.

4.1.1 Responsibility for compliance. All items must meet all requirements of sections 3 and 5. The inspection set forth in this specification shall become a part of the contractor's overall inspection system or quality program. The absence of any inspection requirements in the specification shall not relieve the contractor of the responsibility of ensuring that all products or supplies submitted to the Government for acceptance comply with all requirements of the contract. Sampling inspection, as part of manufacturing operations, is an acceptable practice to ascertain conformance to requirements, however, this does not authorize submission of known defective material, either indicated or actual, nor does it commit the Government to accept defective material.

4.2 Classification of inspections. The inspection requirements specified herein are classified as follows:

- a. First article inspection (see 4.3).
- b. Quality conformance inspection (see 4.4).

4.3 First article inspection. First article inspection shall consist of the tests specified in Table VII. A sufficient number of first article test samples (see 4.3.1) to conduct the tests in Table VII shall be forwarded to and tested by a laboratory approved by the procuring activity (see 6.2 and 6.6). All material supplied to this specification shall be manufactured using the same formulation and methods used to obtain the first article samples unless a change has been approved by the procuring activity.

4.3.1 First article test samples. Except as indicated below, first article test specimens shall be fabricated from the end items. If the end items for sheet, strip, or extrusions are of such shapes that suitable test specimens can not be obtained from them, the test specimens shall be fabricated from a test extrusion. The test extrusion shall be prepared from tubing $1.000 \pm .016$ inch (25.4 ± 0.41 mm) OD by 0.075 ± 0.008 inch (1.9 ± 0.2 cm) in wall thickness which has been mechanically split and flattened into a strip and subsequently cured. The test extrusion shall be composed of the same batch of rubber and cured under the same conditions as the material it represents. If the end items for molded parts are of such shapes that suitable test specimens can not be cut from them, the test specimens shall be fabricated from molded test slabs $6 \times 6 \times 0.075$ in. ($150 \times 150 \times 1.9$ mm). The test slabs shall be molded from the same batch of rubber and cured under the same conditions as the molded parts they represent.

4.3.1.1 Data to be submitted with first article samples. The supplier shall submit two copies of the first article inspection report showing conformance to the test requirements in Table VII (see 6.3).

4.3.2 Prior approval. If a contractor has previously delivered material in accordance with the requirements of this specification and the product has been found to be satisfactory, the requirements for first article inspection for that product, in connection with any subsequent contract or order for that product, may be waived at the discretion of the procuring activity (see 6.2). The approval of first article samples or the waiving of the first article inspection shall not relieve the contractor of his obligation to fulfill all other requirements of this specification and the contract.

4.3.3 Certified statement. Whether or not first article inspection is required (see 4.3.2), the contractor shall certify in writing that the material meets all the requirements of this specification (see 6.3).

TABLE VII. First article tests.

Property	Specification reference		Number of Tests To Be Conducted	Report Results As	Report Numerically to nearest
	Requirement	Test method			
Properties Under Standard Conditions Per 4.5.1 (all Classes):				1/	2/
Hardness.....	3.6	4.6.1.1	1	Average of 5 Readings	unit
Tensile strength.....	3.6	4.6.1.2	5	Median of 5 Tests	10 psi
Elongation.....	3.6	4.6.1.2	5	Median of 5 Tests	5 percent
Specific gravity.....	3.6	4.6.1.3	2	Average of 2 Tests	unit
Properties After Accelerated Aging Per 4.6.2 (all Classes):					
Hardness change (points).....	3.6	4.6.2.2	1	Average of 5 Readings	unit
Tensile strength Change (%).....	3.6	4.6.2.3	5	Median of 5 Tests	percent
Elongation Change (%).....	3.6	4.6.2.3	5	Median of 5 Tests	percent
Weight change (%).....	3.6	4.6.2.4	3	Average of 3 Tests	percent
Compression set.....	3.6	4.6.2.5	2	Average of 2 Tests	percent
Properties After Water Immersion Per 4.6.3.4.1 (all Classes):					
Hardness Change (points).....	3.6	4.6.3.1	1	Average of 5 Readings	unit
Volume Change (%).....	3.6	4.6.3.3	3	Average of 3 Tests	percent
Properties After Oil Immersion Per 4.6.3.4.2 (Classes 1, 2, and 4 as Applicable):					
Hardness Change (points).....	3.6	4.6.3.1	1	Average of 5 Readings	unit
Volume change (%).....	3.6	4.6.3.3	3	Average of 3 Tests	percent
Tensile strength Change (%).....	3.6	4.6.3.2	5	Median of 5 Tests	percent
(Classes 2 and 4 only)					
Volume Change (%) After Fuel Immersion per 4.6.3.4.3 (Class 1):					
Aromatic Type (Phase A).....	3.6	4.6.3.3	3	Average of 3 Tests	percent
Alkylate Type (Phase B).....	3.6	4.6.3.3	3	Average of 3 Tests	percent
Drying (Phase C).....	3.6	4.6.3.3	3	Average of 3 Tests	percent
Ozone resistance (classes 2 and 4).....	3.6.2	4.6.1.4	2	Pass/Fail For Each Test	---
Low temperature Resistance (Cold Bend Test):					
Class 1.....	---	4.6.4			---
Classes 2, 3, 4, and 5.....	3.6.4.1	4.6.4.1.1	3	Pass/Fail For Each Test	---
Crazing (Classes 4 and 5).....	3.6.4.1	4.6.4.1.2	3	Pass/Fail For Each Test	---
	3.6.3	4.6.1.5	4	Pass/Fail For Each Test	---

1/ If failure is indicated, report description of failure.
 2/ Test reports shall include all values on which results are based.

4.4 Quality conformance inspection.

4.4.1 Lot formation. A lot shall consist of all items of the same form (such as sheet), manufactured from the same lot of rubber, processed in one continuous run and ready for inspection at one time. A lot of rubber shall be the amount of compounded material run through a mill or mixer at the same time.

4.4.2 Sampling and inspection.

4.4.2.1 Visual examination for workmanship.

4.4.2.1.1 Molded parts. Samples of molded parts for visual examination and product marking shall be selected in accordance with MIL-STD-105, Inspection Level II. The sample unit shall be one molded part. Each sample unit selected from the lot shall be examined for defects as specified in MIL-STD-407. Acceptance criteria shall be as specified in the contract or purchase order (see 6.2 and 6.7).

4.4.2.1.2 Sheets, strips and extruded shapes. Samples of sheets, strips and extruded shapes for visual examination and product marking shall be selected in accordance with MIL-STD-105, Inspection Level II. The sample unit shall be one yard (0.91 meters). Each sample unit selected from the lot shall be examined for defects as specified in MIL-STD-289 for sheet and strip, and MIL-STD-298 for extruded shapes. Defects in marking, such as incomplete, not legibly identified, or as specified in 3.9, shall be considered minor. Acceptance criteria shall be as specified in the contract or purchase order (see 6.2 and 6.7).

4.4.2.1.2.1 Examination of rolls of sheet form for defects in workmanship. In addition to the inspection requirements in 4.4.2.1.2, samples of sheet material supplied in rolls shall be examined for defects in workmanship as specified in Table VIII. The sample unit shall be one roll selected in accordance with MIL-STD-105, Inspection Level II. Acceptance criteria shall be as specified in the contract or purchase order (see 6.2 and 6.7).

TABLE VIII. Defects for sheet material supplied in rolls.

Any cut-out larger than four inches (10cm) diameter.
More than four cut-outs per roll.
More than two cut-outs in any 10 linear feet (3m).
Roll contains more than three pieces. Each piece shall be not less than 20 percent of the length of the entire roll.

4.4.2.2 Dimensional examination.

4.4.2.2.1 Molded parts. Samples of molded parts for dimensional examination shall be selected in accordance with MIL-STD-105, Inspection Level II. The sample unit shall be one molded part. Each sample unit selected from the lot shall be dimensionally examined for conformance to 3.4.3. Acceptance criteria shall be as specified in the contract or purchase order (see 6.2 and 6.7).

4.4.2.2.2 Sheets, strips and extruded shapes. Samples of sheets, strips and extruded shapes for dimensional examination shall be selected in accordance with MIL-STD-105, Inspection Level II. The sample unit shall be one yard. Each sample unit selected shall be dimensionally examined for conformance to 3.4.1 or 3.4.2, as applicable. Acceptance criteria shall be as specified in the contract or purchase order (see 6.2 and 6.7).

4.4.2.3 Examination of packaging. An examination shall be made to determine that the packaging, packing and marking comply with the requirements of Section 5 of this specification. The sample unit for this examination shall be one shipping container, fully packed, selected just prior to the closing operation. The shipping container, fully prepared for delivery, shall be examined for closure defects. Samples shall be selected in accordance with MIL-STD-105, Inspection Level II. Each shipping container selected as a sample unit shall be examined for defects in packaging, packing and marking in accordance with Table IX. Acceptance criteria shall be as specified in the contract or purchase order (see 6.2 and 6.7).

TABLE IX. Preservation, packing, and marking defects.

Examine	Defect
Preservation	Not level specified (see 5.1).
Packing (all forms)	Not level specified (see 5.2).
	Container not as specified; closures not accomplished by specified or required methods or materials (see 5.2)
	Any nonconforming component; component missing, damaged or otherwise defective affecting serviceability (see 5.2) Inadequate application of components, such as: incomplete closures of case liners, container flaps, loose or inadequate strapping, bulged or distorted containers (see 5.2).
Packing (flat sheets)	Paper between sheets or dusting powder missing or not extending over full area between sheets (see 5.2.1a)
	Container inside height exceeds 10 inches (.25 m) (see 5.2.1a)
	Sheets are compressed or deformed in packing arrangement (see 5.2.1a)
Packing (rolls of strip and sheet)	Paper or dusting powder (as applicable) missing or does not cover full area of contact of the rubber strip or sheet (see 5.2.1b and c).
	Length of rolls not as specified; individual rolls not wrapped, not sealed (see 5.2.1b and c).
	Core doesn't provide rigid support (see 5.2.1b and c)
	More than one roll per shipping container (see 5.2.1b and c).
Packing (extrusions)	Lengths 14 feet (4.3 m) or less not packed in straight lengths; longer than 14 feet (4.3 m) not coiled (without deformation) (see 5.2.1d).
	Dusting powder missing or doesn't cover the entire outside area of the extruded shape (see 5.2.1d).
	Extruded shapes other than tubing not wrapped in full length with a suitable paper or plastic sleeving (see 5.2.1d)
Packing (molded shapes & small pieces)	Not packed in accordance with MIL-P-4861 (see 5.2.1e).
	Not individually wrapped; not packed to prevent deformation (see 5.2.1e).
Marking	Interior or exterior markings (as applicable) omitted, illegible, incorrect, incomplete, or not in accordance with contract requirements (see 5.3)
Count	Less than specified or indicated linear feet or quantity of sheets, shapes, tubes, or strips, as applicable (see 6.2).

4.4.2.4 Physical and mechanical property tests. Physical and mechanical property testing shall be conducted in accordance with Table X. A sufficient quantity of the synthetic rubber items to conduct the tests in Table X shall be selected at random from each lot.

4.4.2.4.1 Test specimens. Except as indicated below, test specimens shall be fabricated from the items supplied in the lot. If sheet, strip, or extrusions are supplied in such shapes that suitable test specimens can not be obtained from them, the test specimens shall be fabricated from a test extrusion. The test extrusion shall be prepared from tubing 1.000 ± 0.016 (25.4 ± 0.41 mm) OD by 0.075 ± 0.008 inch (1.9 ± 0.2 cm) in wall thickness which has been mechanically split and flattened into a strip and subsequently cured. The test extrusion shall be composed of the same batch of rubber and cured under the same conditions as the lot of material it represents. If molded items are supplied in such shapes that suitable test specimens can not be cut from them, the test specimens shall be fabricated from molded test slabs $6 \times 6 \times 0.075$ in. ($150 \times 150 \times 1.9$ mm). The test slabs shall be molded from the same batch of rubber and cured under the same conditions as the lot of molded parts they represent.

4.4.2.4.2 Rejection criteria. Failure of any sample to meet the test requirements specified herein shall result in rejection of the lot.

4.5 Inspection conditions. All test specimens shall be conditioned and tested at standard conditions, unless otherwise specified herein.

4.5.1 Standard conditions. Standard conditions shall be $75^\circ \pm 5^\circ\text{F}$ ($24^\circ \pm 3^\circ\text{C}$) and 50 ± 5 percent relative humidity.

4.6 Test methods.

4.6.1 Tests under standard conditions (see 4.5.1).

4.6.1.1 Hardness. Hardness testing shall be determined on one specimen in accordance with ASTM D2240. The hardness shall be the average of 5 readings for each specimen tested.

4.6.1.2 Tensile strength and elongation. Tensile strength and elongation shall be determined on at least five specimens in accordance with ASTM D412 using Die C to obtain specimens.

4.6.1.3 Specific gravity. Specific gravity shall be determined on two specimens in accordance with ASTM D792.

4.6.1.4 Ozone resistance test (Classes 2 and 4). Type A specimens shall be prepared in accordance with ASTM D518, procedure A. Type B specimens shall be prepared in accordance with ASTM D518, procedure B. Specimens shall be tested in accordance with ASTM D1149. Ozone concentration, expressed in ozone partial pressures, shall be 100 ± 5 mPa for Type A material and 50 ± 5 mPa for Type B material. Exposure period for Type A and Type B specimens shall be 168 hours minimum. Observation magnification shall be 7x.

TABLE X. Quality conformance physical and mechanical tests.

Property	Specification reference		Number of Tests To Be Conducted	Report Results As	Report Numerically To Nearest
	Requirement	Test method			
Properties Under Standard Conditions Per 4.5.1 (all Classes):	Hardness.....	4.6.1.1	1	Average of 5 Readings	unit
	Tensile strength.....	4.6.1.2	5	Median of 5 Tests	10 psi
	Elongation.....	4.6.1.2	5	Median of 5 Tests	5 percent
	Specific gravity.....	4.6.1.3	2	Average of 2 Tests	unit
Properties After Accelerated Aging Per 4.6.2 (all Classes):	Compression set.....	4.6.2.5	2	Average of 2 Tests	percent
	Properties After Oil Immersion Per 4.6.3.4.2 (Classes 1, 2, and 4)				
Hardness Change (points).....	3.6	4.6.3.1	1	Average of 5 Readings	unit
	3.6	4.6.3.3	3	Average of 3 Tests	percent
Volume Change (%) After Fuel Immersion per 4.6.3.4.3 (Class 1):	3.6	4.6.3.3	3	Average of 3 Tests	percent
	3.6.2	4.6.1.4	2	Pass/Fail For Each Test	---
Ozone resistance (classes 2 and 4) 3/.....	3.6.3	4.6.1.5	4	Pass/Fail For Each Test	---

1/ If failure is indicated, report description of failure.

2/ Test reports shall include all values on which results are based.

3/ Tests for ozone resistance and crazing are performed only when specified in the contract or purchase order (see 6.2)

4.6.1.5 Crazing test (Classes 4 and 5). Eight plastic strips, 1 by 7 by 0.25 inches (25.4 by 177.8 by 6.4 mm), shall be prepared. Four shall be cut from a piece of acrylic plastic conforming to MIL-P-5425, Finish A and four shall be cut from a piece of polycarbonate plastic conforming to MIL-P-83310. The plastic shall be cleaned with aliphatic naphtha conforming to TT-N-95 and then allowed to air-dry at standard conditions for a minimum of 24 hours prior to testing. As specified on Figure 1, the plastic strips shall be set up as cantilever beams in a circulating air oven maintained at a temperature of $110^{\circ} \pm 2^{\circ}\text{F}$ ($43^{\circ} \pm 1^{\circ}\text{C}$) for 70 ± 1 hours. The beams shall be loaded to produce an outer fiber tensile stress of 2,000 Psi (13.8 MPa) at the fulcrum as determined in 4.6.1.5.1. Ten minutes after the beams have been stressed, they shall be examined for crazing. Beams in which crazing has occurred shall be replaced with others that pass the 10 minute test. Classes 4 and 5 specimens, 1 by 2 by 0.075 inches (25.4 by 50.8 by 1.9 mm), shall be placed in intimate contact with three of the acrylic beams and three of the polycarbonate beams directly over the fulcrum. The specimens shall be held in firm contact with the surface of the plastic strips by applying a small load (3 ounce (85.1 grams) shot bag) on top of each rubber specimen. The remaining two beams, under the same stress without rubber specimen, shall be employed as controls. The examinations for crazing shall be made while the plastic is under stress, at the end or at any time within the 70 ± 1 hours test period. The beams with rubber specimens removed, shall be observed for crazing over a source of light at such an angle that the light will be reflected to the eye from the surfaces of any crazing fissures which are present. To prevent overheating of beams, the light source shall be utilized only during examination for crazing. In the event that crazing occurs in one of the controls, the test shall be repeated for that particular plastic. Edge crazing, when observed within 0.125 inch (3.2 mm) from the edge of beam, shall be disregarded.

4.6.1.5.1 Calculation. The load required for each beam shall be calculated as follows:

$$P = \frac{SBD^2}{24}$$

Where:

- P = Load in pounds (kg) (applied at free end of beam - 4 inches (10.2 cm) from fulcrum).
- B = Width of plastic strip (measured to nearest 0.001 inch (0.025 mm)).
- D = Depth of plastic strip (measured to nearest 0.001 inch (0.025 mm)).
- S = Stress in pounds per square inch (MPa) = 2,000 (13.8).

4.6.2 Tests after accelerated aging (oven-aged).

4.6.2.1 Test conditions. The required specimens for each test to be conducted shall be subjected to accelerated aging for 70 ± 1 hours in an air circulating oven at a temperature of $212^{\circ} \pm 2^{\circ}\text{F}$ ($100^{\circ} \pm 1^{\circ}\text{C}$). After the aging period, the specimens shall be removed from the oven and allowed to rest at standard conditions for not less than 16 hours nor more than 70 hours, before being subjected to tests for change in hardness, tensile strength, elongation and weight. For the determination of compression set, the specimen shall be removed from the compression fixture after the aging period and allowed to rest on a wood surface at standard conditions for at least 30 minutes before compression set is determined.

4.6.2.2 Change in hardness. A specimen from either the change in tensile strength (see 4.6.2.3) or the change in weight (see 4.6.2.4) test shall be used to determine the change in hardness. After aging in accordance with 4.6.2.1, the hardness value shall be determined in accordance with 4.6.1.1. The change in hardness determination shall be expressed as change in hardness points from the standard condition value.

4.6.2.3 Percent change in tensile strength and elongation. The tensile strength and elongation properties shall be determined in accordance with 4.6.1.2 after aging the specimens in accordance with 4.6.2.1. The results expressed as percent change for each mechanical property shall be calculated as follows:

$$\% \text{ change} = \frac{A - O}{O} \times 100$$

Where:

O = Standard condition value.
A = Value after aging.

4.6.2.4 Percent Change in weight. Three specimens approximately 1 by 2 by 0.075 inches (2.5 by 5.1 by .19 cm) in thickness shall be used. The specimens shall be held over night in a desiccator and weighed to the nearest milligram (mg) before being subjected to oven aging as specified in 4.6.2.1. After oven aging, the specimens shall be cooled in a desiccator for not less than 2 hours nor more than 70 hours and again weighed to the nearest mg. The change in weight shall be calculated as follows:

$$\% \text{ change in weight} = \frac{W2 - W1}{W1} \times 100$$

Where:

W1 = Initial weight.
W2 = Weight after oven aging.

4.6.2.5 Compression set. Compression set determination shall be conducted in accordance with ASTM D395, Method B. After oven aging as specified in 4.6.2.1, the specimens shall be removed from the compression fixture and allowed to rest on a wood surface at standard conditions for at least 30 minutes before compression set is determined.

4.6.3 After immersion tests (water, oil, and fuel).

4.6.3.1 Change in hardness. Change in hardness shall be determined after water immersion for all Classes and after oil immersion for Classes 1, 2, and 4. Conditioning of the specimens for water and oil immersion shall be as specified in 4.6.3.4.1 and 4.6.3.4.2 respectively. Specimens from either the change in tensile strength (see 4.6.3.2) or volume (see 4.6.3.3) tests shall be used to determine change in hardness. After conditioning, the hardness value shall be determined in accordance with 4.6.1.1. The change in hardness determination shall be expressed as the change in hardness points from the standard condition value.

4.6.3.2 Change in tensile strength. Change in tensile strength shall be determined after oil immersion for Classes 2 and 4. After conditioning in accordance with 4.6.3.4.2, the tensile strength and elongation properties shall be determined in accordance with 4.6.1.2 using the specimens original unconditioned cross sectional area for the calculation of tensile strength. The results expressed as percent change for each mechanical property shall be calculated as follows:

$$\% \text{ change} = \frac{I - O}{O} \times 100$$

Where:

O = Standard condition value.
I = Value after Immersion.

4.6.3.3 Change in volume. Change in volume shall be determined after water immersion for all Classes, oil immersion for Classes 1, 2, and 4, and fuel immersion for Class 1. Each test shall be conducted using three specimens 1 by 2 by 0.075 inches (2.5 by 5.1 by .19 cm). Prior to conditioning, the specimens shall be weighed in air and then in water using an analytical balance. As applicable for the Class being tested, the specimens shall then be conditioned for water, oil, and fuel immersion as specified in 4.6.3.4.1, 4.6.3.4.2, and 4.6.3.4.3 respectively. After conditioning, the specimens shall be reweighed in air and then in water by means of a jolly or analytical balance. Percentage change in volume shall be based on the original unconditioned volume and shall be calculated as follows:

$$\% \text{ change in volume} = \frac{(W3 - W4) - (W1 - W2)}{(W1 - W2)} \times 100$$

Where:

W1 = Initial (unconditioned) weight in air.
W2 = Initial (unconditioned) weight in water.
W3 = Weight in air after immersion.
W4 = Weight in water after immersion.

4.6.3.4 Water, oil, and fuel immersion conditioning.

4.6.3.4.1 Water immersion conditioning. Specimens shall be completely immersed in distilled water in accordance with ASTM D471 for 70 ± 1 hours at $212^\circ \pm 2^\circ\text{F}$ ($100^\circ \pm 1^\circ\text{C}$). At the end of the immersion period, the specimens shall be removed from the hot liquid and immediately immersed in fresh distilled water at standard conditions for 30 ± 5 minutes. The test specimens shall then be dipped rapidly in acetone or alcohol, blotted lightly, and tested within 3 minutes.

4.6.3.4.2 Oil immersion conditioning (Classes 1, 2 and 4). Classes 1, 2 and 4 specimens shall be completely immersed in oil No. 1 in accordance with ASTM D471 for 70 ± 1 hours at $212^\circ \pm 2^\circ\text{F}$ ($100^\circ \pm 1^\circ\text{C}$). At the end of the immersion period, the specimens shall be removed from the hot oil and immediately immersed in fresh oil No. 1 at standard conditions for 30 ± 5 minutes. Test specimens shall then be dipped rapidly in acetone or alcohol, blotted lightly, and tested within 3 minutes.

4.6.3.4.3 Fuel immersion (Class 1 volume change only). Class 1 specimens shall be successively exposed to the following phases of fuel immersion conditioning to determine change in volume:

- Phase A Immersion in Fuel B of ASTM D471, for 7 days at standard conditions.
- Phase B Immersion in Fuel A of ASTM D471, for 7 days at standard conditions.
- Phase C Dried at standard conditions for at least 16 hours, and followed by a drying for 4 hours in a circulating air oven at a temperature of $158^{\circ} \pm 2^{\circ}\text{F}$ ($70^{\circ} \pm 1^{\circ}\text{C}$).

Each specimen shall be exposed to phases A, B and C successively, determining volume change in accordance with 4.6.3.3 after exposure to each phase. Prior to determining volume change after phase A and phase B exposure, the test specimens shall be removed from the immersion medium, dipped rapidly in acetone or alcohol, blotted lightly, and tested within 3 minutes. The period between phases A and B, during which the specimens are not immersed, shall not exceed 30 minutes.

4.6.4 Low temperature tests (cold bend). Three strips 5.50 by 0.25 by 0.075 inches (140 by 6.4 by 1.9 mm) shall be used for the cold bend test. The bending device shall consist of two parallel jaws of suitable length, 2.5 inches (64 mm) apart, and designed to hold three specimens in a loop position between the jaws with each end of the specimen firmly fastened to the jaws and extending at least 0.75 inch (19.1 mm) into each jaw. The moving jaw shall be loaded with a dead load of 50 pounds (22.68 kg). The jaws shall be supported in guides so that they may be rapidly closed to 1 inch (25.4 mm) by releasing the dead load.

4.6.4.1 Procedure.

4.6.4.1.1 Class 1. Class 1 synthetic rubber specimens shall first be conditioned as follows:

Soak in Fuel B of ASTM D471 for 3 hours under reflux at $158^{\circ} \pm 2^{\circ}\text{F}$ ($70^{\circ} \pm 1^{\circ}\text{C}$). Soak in Fuel A of ASTM D471 for 3 hours under reflux at $158^{\circ} \pm 2^{\circ}\text{F}$ ($70^{\circ} \pm 1^{\circ}\text{C}$). Transfer of specimens from Fuel B to Fuel A shall be made within a period of 1 hour. After removal from Fuel A, specimens shall be dried at standard conditions on a wire screen for not less than 16 hours nor more than 24 hours.

After the above conditioning, the specimens shall be mounted in the preconditioned apparatus, immersed in preconditioned Fuel A of ASTM D471, and exposed to a temperature of $-67^{\circ} \pm 2^{\circ}\text{F}$ ($-55^{\circ} \pm 1^{\circ}\text{C}$). After 300 ± 15 minutes exposure, the specimens shall be flexed while still immersed and in the cold chamber, and examined for evidence of cracking.

4.6.4.1.2 Classes 2, 3, 4 and 5. Classes 2, 3, 4 and 5 synthetic rubber specimens shall be mounted in the preconditioned apparatus, exposed to a temperature of $-67^{\circ} \pm 2^{\circ}\text{F}$ ($-55^{\circ} \pm 1^{\circ}\text{C}$) for 300 ± 15 minutes and flexed while still in the cold chamber, and examined for evidence of cracking.

4.7 Color. If material covered by this specification is required to be of a specified color, quality assurance provisions for examination of color shall be included in the contract or purchase order (see 3.7 and 6.2).

5. PACKAGING

5.1 Preservation. Preservation shall be Level A or Commercial, as specified (see 6.2).

5.1.1 Level A.

5.1.1.1 Molded shapes and small pieces. Individual molded shapes and small pieces (see 3.9.3) shall be preserved in individual envelopes (one part per envelope) in accordance with MIL-P-4861 as specified by the procuring activity (see 6.2).

5.1.1.2 Sheets, strips, and extruded shapes. Preservation (interior packaging) of sheets, strips, and extruded shapes is not required.

5.1.2 Commercial. Synthetic rubber forms shall be preserved in accordance with the applicable requirements of ASTM D3951.

5.2 Packing. Packing shall be Level A, B, C, or Commercial, as specified (see 6.2 and 6.4). Shipping containers shall contain synthetic rubber of the same class, type (when applicable), grade, form, and size, and shall be designed to enclose the contents in a snug tight-fitting manner. The gross weight of the shipping container shall not exceed 200 pounds (90.7 kg).

5.2.1 Level A. Synthetic rubber forms shall be packed for shipment, as specified below for the various items covered by this specification (see 1.2.3), in cleated boxes conforming to PPP-B-601, Overseas Type. Closure shall be in accordance with the appendix of the applicable specification.

- a. Flat sheets: Paper or talc dusting powder shall be used between the sheets extending over the full area of contact between the sheets. The inside height of the container shall not exceed 10 inches (254 mm). When specified by the procuring activity, a small quantity of sheets having a maximum thickness not exceeding 2.5 inches (64 cm) may be baled. The sheets shall be packed so they will not become deformed or compressed in shipment or extended storage.
- b. Roll sheets: Paper, plastic film, or talc dusting powder shall be used to cover the full area of contact of the rubber sheet. Each roll shall contain the number of feet (meters) specified, wound on cores which will provide rigid support and which will not distort or change shape during handling or shipment. One roll of rubber shall be packed in the shipping container. Each roll shall be wrapped in heavy kraft paper or plastic film and sealed with paper or tape before packing in the shipping container.

- c. Strip: Paper, plastic film, or talc dusting powder shall be used to cover the full area of contact of the rubber strip. One roll of rubber strip shall be packed in the shipping container. Each roll shall contain the number of feet (meters) specified, wound on cores which will provide rigid support and which will not distort or change shape during handling or shipment. Each roll shall be wrapped in heavy kraft paper or plastic film and sealed with paper or tape before packing in the shipping container.
- d. Extruded shapes: Talc dusting powder shall be used to cover the entire outside area of the extruded shapes. Extrusions, 14 feet (4.3 m) or less in length, shall be packed in straight lengths. Lengths of extrusions greater than 14 feet (4.3 m) may be coiled, provided the inside diameter of the coil is large enough to preclude the possibility of permanent deformation or set during shipment and extended storage. Except for tubing, each shape shall be wrapped full length in paper or plastic film sleeving before placing in the shipping container. The tube section of coiled extrusions shall always be on the inside to prevent permanent distortion due to stress of coiling.
- e. Molded shapes and small pieces: Molded shapes and small pieces preserved in accordance with 5.1.1.1, shall be packed in accordance with MIL-P-4861.

5.2.2 Level B. Synthetic rubber forms shall be packed for shipment as specified in 5.2.1a through 5.2.1e, in fiberboard boxes conforming to PPP-B-636, weather resistant Class, or PPP-B-640, Class 2. Molded shapes and small pieces as specified in 5.2.1(e), shall be packed for shipment in accordance with MIL-P-4861. Closure and sealing shall be in accordance with the appendix of the applicable specification.

5.2.3 Level C. Synthetic rubber forms shall be packed in accordance with the applicable requirements of MIL-STD-2073-1.

5.2.4 Commercial. Synthetic rubber forms shall be packed in accordance with the applicable requirements of ASTM D3951.

5.3 Marking.

5.3.1 Shelf life markings. Shelf life markings and marking of interior packages and shipping containers shall be marked in accordance with MIL-STD-129 or ASTM D3951 as applicable and the requirements herein. The cure date and "use by" date shall be indicated by quarter and year (for example: 3Q86 indicates the third quarter of calendar year 1986) (see 3.8, 3.9, and 6.2).

5.3.2 Precautionary marking. The following precautionary marking shall be included on each shipping container.

STORE IN A COOL DRY PLACE

5.4 Palletization. Unitized loads, commensurate with the level of packing specified in the contract or purchase order (see 6.2), shall be palletized in accordance with MIL-STD-147. Palletized loads shall be uniform in size and quantities to the greatest extent possible. If the container is of a size which does not conform to any of the pallet patterns specified in MIL-STD-147, the pallet pattern used shall first be approved by the procuring activity.

6. NOTES

(This section contains information of a general or explanatory nature that may be helpful, but is not mandatory)

6.1 Intended use. The material covered by this specification is intended for use where synthetic rubber is required for a specific application, such as:

6.1.1 Class 1. Class 1 material is intended for use where resistance to aromatic, alkylate or aviation fuel, and petroleum base lubricants is required.

6.1.2 Class 2. Class 2 material is intended for use where resistance to petroleum base lubricants and exposure to the elements is required.

6.1.2.1 Type A. Type A is intended for use where high concentrations of ozone exist in the atmosphere, particularly along the east and west coasts of the United States. Type B is intended for general use.

6.1.3 Class 3. Class 3 material is intended for general use where resistance to oil and fuel and the elements is not required.

6.1.4 Classes 4 and 5. Classes 4 and 5 material are intended for general use in contact with acrylic plastics.

6.1.4.1 Class 4. Class 4 material is intended for use in applications requiring maximum resistance to the elements and petroleum base oil, and requires the same usage under Type A or Type B as indicated in 6.1.2.1.

6.1.4.2 Class 5. Class 5 material is intended for use where low temperature flexibility is required ($-67^{\circ} \pm 2^{\circ}\text{F}$ ($-55^{\circ} \pm 1^{\circ}\text{C}$)). Class 5 is not recommended for use with petroleum base oil, or where sunlight and ozone resistance is required.

6.1.5 Elastomers known to comply with the specific classes of this specification are as follows:

- Class 1 Nitrile-Butadiene
- Class 2 Polychloroprene
- Class 3 Styrene-butadiene
- Class 4 Polychloroprene
- Class 5 Styrene-butadiene

Polyurethane rubber shall not be supplied to this specification due to its lack of hydrolytic stability and the release of toxic fumes when burned.

6.1.6 U.S. Army Electronics Command use. Use of this specification for U.S. Army Electronics Command is restricted to Class 4 and Class 5.

6.2 Acquisition requirements. Acquisition documents should specify the following:

- a. Title, number, and date of this specification and applicable specification sheet.
- b. Military part number (if any), Class, Grade, Form, dimensions, amount required (see 1.2, 3.4, and 6.2.1).
- c. Type for ozone resistance required for Classes 2 and 4 (see 3.6.1 and 4.6.1.4).
- d. Issue of the DODISS to be cited in the solicitation, and if required, the specific issue of individual documents referenced (see 2.1.1 and 2.2)
- e. Detail drawings and additional specifications and tolerances, if any (see 3.4 and 3.5), including details of surface finish (if different than that in 3.5) and rubber reinforcement, if any (see 1.1).
- f. Requirements, if any, for color of material and applicable quality assurance provisions (see 3.7 and 4.7).
- g. Shelf life designation and marking requirements to designate the "use by" date (see 3.8 and 5.3.1).
- h. Marking frequency requirements, if other than that specified in 3.9.1 through 3.9.3, as applicable.
- i. Details for first article testing (see 4.3, 4.3.2, and 6.6).
- j. Quality conformance acceptance criteria for visual (see 4.4.2.1), dimensional (see 4.4.2.2), and packaging inspection (see 4.4.2.3).
- k. If testing for ozone resistance and/or crazing is to be performed under quality conformance inspection (see Table X).
- l. Levels of preservation and packing, palletization required, and unit quantities (see Section 5).

6.2.1 Part or Identifying number (PIN). Part numbers should be assigned in accordance with applicable specification sheets to identify items fabricated from synthetic rubber in accordance with this specification. When an item furnished under this specification is not covered by a specification sheet, the manufacturers part number should identify the item. Military part numbers should be coded in accordance with the following example:

EXAMPLE:

M6855/X-XXXXXX

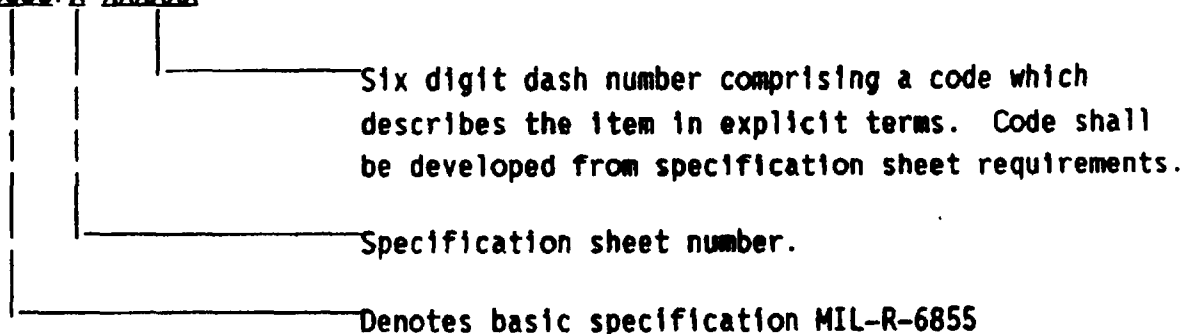

6.3 Consideration of data requirements. The following data requirements should be considered when this specification is applied on a contract. The applicable Data Item Description (DID) should be reviewed in conjunction with the specific acquisition to ensure that only essential data are requested/provided and that the DID is tailored to reflect the requirements of the specific acquisition. To ensure correct contractual application of the data requirements, a Contract Data Requirements List (DD Form 1423) must be prepared to obtain the data, except where DOD FAR Supplement 27-4.75-1 exempts the requirement for a DD Form 1423.

<u>Reference Para.</u>	<u>DID Number</u>	<u>DID Title</u>	<u>Suggested Tailoring</u>
4.3.1.1	DI-NDTI-80809A	TEST/INSPECTION REPORTS	---
4.3.3	"	"	10.2.7.2

The above DID was cleared as of the date of this specification. The current issue of DOD 5010.12-L, Acquisition Management Systems and Data Requirements Control List (AMSDL), must be researched to ensure that only current, cleared DID's are cited on the DD Form 1423.

6.4 Adhesively bonding rubber components. Difficulty has been reported when adhesively bonding rubber sheets due to surface contamination. Possible sources of contamination include the paper or dusting powder used to separate the sheets and latex gloves used to handle the sheets. In preparing documents to acquire material which will be bonded, appropriate measures to avoid this problem should be considered. Such measures would include supplemental specification of methods, materials, and protective gloves for use in production, handling, and packaging, as well as inspections and test methods to ensure that bonding surfaces have not been contaminated.

6.5 Hazards. This specification may involve hazardous materials, operations, and equipment. This specification does not purport to address the safety problems associated with its use. It is the responsibility of the contractor or test activity to establish appropriate safety and health practices, and to consult and determine the applicability of regulatory limitations which may apply.

6.6 First article. The contracting officer should provide specific guidance to offerors whether the first article samples should be a preproduction item, a first production item, a sample selected from the first production items, or a standard production item from the contractors inventory (see 3.1 and 4.3). The contracting officer should also include specific instructions in acquisition documents regarding arrangements for testing, approval of first article test results, and disposition of first articles. Invitations for bids should provide that the Government reserves the right to waive requirements for first article inspection to those bidders offering such products, who wish to rely on such production or test, must furnish evidence with the bid that prior Government approval is presently appropriate for the pending contract. Bidders should not submit alternate bids unless specifically requested to do so in the solicitation.

6.7 Acceptance criteria. The quality conformance acceptance criteria for visual, dimensional, and packaging inspections used in previous revisions of this specification are as specified in Table XI.

TABLE XI. Acceptance criteria in previous revisions.

Inspection	Paragraph	Acceptance Criteria in Previous Revisions
Visual	4.4.2.1.1	AQL of 0.65%
	4.4.2.1.2	AQL of 1.0%
	4.4.2.1.2.1	AQL of 2.5%
Dimensional	4.4.2.2.1	AQL of 0.65%
	4.4.2.2.2	AQL of 1.5%
Packaging	4.4.2.3	AQL of 2.5%

6.8 Subject (key word) listing

Elastomers
 Rubber
 Synthetic Rubber

6.9 Changes from previous issue. Asterisks are not used in this revision to identify changes with respect to the previous issue due to the extensiveness of the changes.

Custodians:

Army - MR
 Navy - AS
 Air Force - 11

Preparing activity:

Navy - AS
 (Project 9320-1093)

Review activities:

Army - AR, AT, AV, CR, ER, MI
 Navy - OS, SH
 Air Force - 82, 99
 DLA - GS, IS, CS

User activities:

Army - CE
 Navy - YD

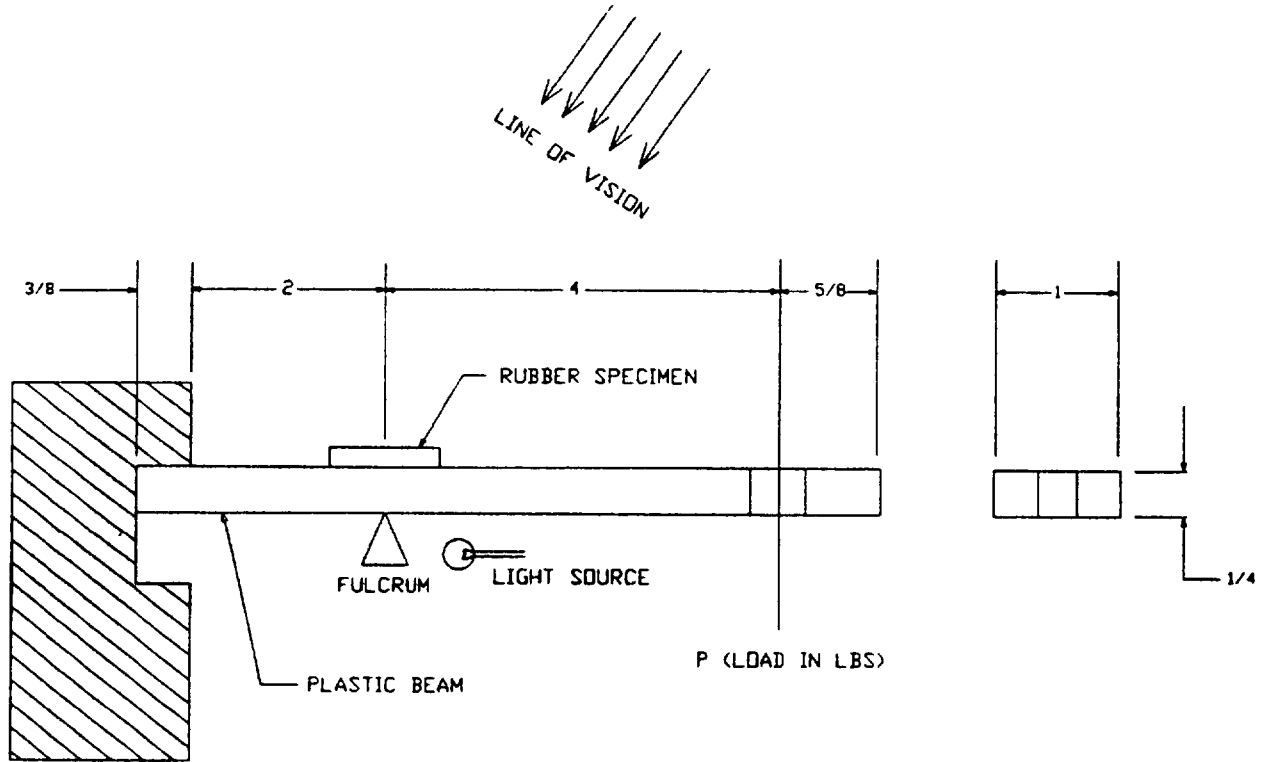

ALL DIMENSIONS ARE IN INCHES.

TOLERANCES:
 PLASTIC BEAMS ± 0.001
 CANTILEVER ± 0.030

FIGURE 1. Sketch showing typical stress crazing beam.